

# PALLADIO

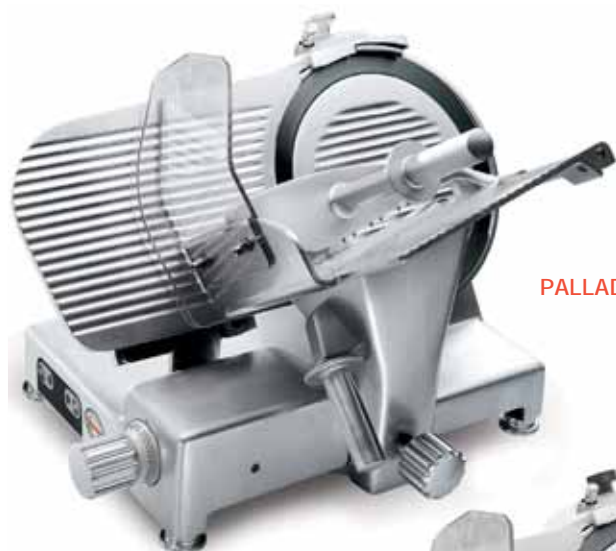

PALLADIO 300 TOP



PALLADIO 300

- Linea arrotondata priva di spigoli e viti a vista
- Perno di scorrimento, cromato rettificato e lappato
- Boccole di scorrimento autolubrificanti
- Paracolpi su carrello in gomma vulcanizzata
- Coperchio supporto vela smontabile
- Parafetta in acciaio inox con incastro a baionetta
- Tutte le minuterie acciaio inox
- Sistema di tenuta stagna su puleggia
- 49,5 mm di distanza fra lama e corpo macchina
- Copertura inferiore
- Pulsanti IP 67 in acciaio inox
- Affilatoio con vaschetta inferiore di protezione
- Estrattore lama di serie
- Inclinazione lama 35°

## PALLADIO

- Manopole plastica
- Piedini in gomma

## PALLADIO TOP

- Manopole alluminio
- Piedini in alluminio telescopici con base in gomma
- Fornitura valigetta utensili

## PALLADIO INGRANAGGI

- Trasmissione con riduttore ermetico a vite senza fine
- Lubrificazione a bagno d'olio
- Non disponibile versione automatica

## PALLADIO AUT

- Pulsantiera ergonomica con pulsanti IP 67
- 3 regolazioni della velocità
- 3 regolazioni della corsa del carrello
- Conteggio delle fette effettuate
- Impostazione delle fette da tagliare con stop automatico della macchina
- Piatto Uniko di serie
- Motore di trasmissione completamente stagno
- Trasmissione del moto con cinghia dentata
- Sistema di sgancio carrello per taglio manuale
- Produzione fette al minuto: 37 - 70

## Opzionali:

- Leva sollevamento
- Piatto Nettuno con sistema di guida prodotto regolabile
- Slitta pesce Poseidon per piatto Uniko

- Rounded design and no sharp edges and visibile screws
- Chrome plated ground and lapped slide rod
- Self lubricating slide rod bushings
- Vulcanized rubber stops on carriage
- Removable support cover for thickness gauge plate
- Stainless steel slice deflector with bayonet fitting
- Stainless steel screws and fittings
- Enclosed and sealed belt pulley
- 49,5 mm distance between blade and motor
- Bottom cover
- Stainless steel pushbuttons with IP67 protection rating
- Built in sharpening tool with bottom protection
- Standard Blade Removal Tool (BRT)
- 35° blade inclination

## PALLADIO

- Plastic knobs
- Rubber feet

## PALLADIO TOP

- Knobs aluminum
- Aluminium telescopic feet with rubber base
- Maintenance tool kit

## PALLADIO INGRANAGGI

- Enclosed and sealed worm gear reduction unit
- Oil bath lubrication
- Automatic model unavailable

## PALLADIO AUT

- Ergomic controls - push buttons with IP67 protection rating
- 3 speed selection
- 3 different adjustments for carriage travel
- Slice counter
- Slice number setting with automatic stop feature
- Standard Uniko hopper
- Enclosed and sealed drive motor
- Positive drive belt
- Carriage release system for manual slicing
- Output slices per minute: 37 - 70

## Options:

- Lifting lever
- Carriage "Nettuno" available with a special end weight and an adjustable vertical product fence to provide stability and advance products evenly
- Poseidon fish cutting for Uniko hopper



Piatto Uniko di serie  
Standard Uniko hopper

PALLADIO 330 TOP AUT.



Ampio spazio tra lama e corpo macchina  
More space between blade and body machine



Spazioso piano per appoggio prodotto  
Large tray



Comandi Palladio AUT  
Palladio AUT controls



Leva sollevamento, opzionale  
Lifting lever, optional



**Palladio Ingranaggi**  
Riduttore a bagno d'olio  
Oil bath gear box



Palladio AUT Piatto Nettuno opzionale  
Palladio AUT with optional Nettuno hopper



Estrattore lama  
Blade Removal Tool (BRT)



Valigetta con kit di manutenzione di serie su versioni Top  
Small suitcase with maintenance kit standard on Top versions



Slitta pesce Poseidon per piatto Uniko opzionale  
Optional Poseidon fish cutting for Uniko hopper

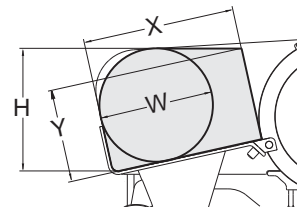
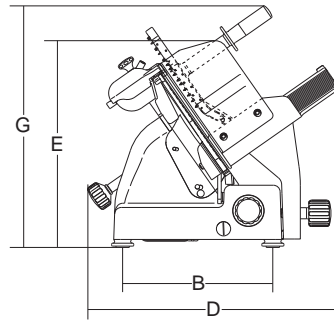
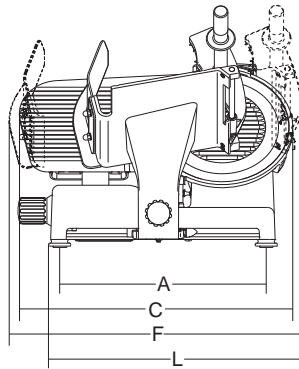

|                   | mm-inch | watt-Hp               | mm | mm  | mm      | A   | B   | C   | D   | E   | F   | G   | L   | X   | Y   | H   | W   | kg | mm          | kg |
|-------------------|---------|-----------------------|----|-----|---------|-----|-----|-----|-----|-----|-----|-----|-----|-----|-----|-----|-----|----|-------------|----|
| Palladio 300      | 300/12" | 275/0,37              | 23 | 310 | 305x270 | 465 | 340 | 615 | 547 | 465 | 710 | 545 | 600 | 270 | 190 | 240 | 220 | 35 | 760x640x700 | 44 |
| Palladio 300 Ingr | 300/12" | 400/0,54              | 23 | 310 | 305x270 | 465 | 340 | 615 | 547 | 465 | 710 | 545 | 600 | 270 | 190 | 240 | 220 | 36 | 760x640x700 | 45 |
| Palladio 300 Aut  | 300/12" | 275+200/<br>0,37+0,27 | 23 | 310 | 305x270 | 465 | 340 | 622 | 620 | 513 | 647 | 528 | 558 | 270 | 190 | 240 | 220 | 38 | 870x840x750 | 53 |
| Palladio 330      | 330/13" | 275/0,37              | 23 | 310 | 305x270 | 465 | 340 | 645 | 570 | 455 | 710 | 535 | 586 | 270 | 210 | 260 | 240 | 36 | 760x640x700 | 45 |
| Palladio 330 Ingr | 330/13" | 400/0,54              | 23 | 310 | 305x270 | 465 | 340 | 645 | 570 | 455 | 710 | 535 | 586 | 270 | 210 | 260 | 240 | 37 | 760x640x700 | 46 |
| Palladio 330 Aut  | 330/13" | 275+200/<br>0,37+0,27 | 23 | 310 | 305x270 | 465 | 340 | 649 | 611 | 515 | 665 | 530 | 563 | 270 | 210 | 260 | 240 | 39 | 870x840x750 | 54 |
| Palladio 350      | 350/14" | 370/0,50              | 23 | 310 | 305x270 | 465 | 340 | 660 | 575 | 455 | 710 | 530 | 580 | 270 | 225 | 275 | 250 | 37 | 760x640x700 | 46 |
| Palladio 350 Ingr | 350/14" | 400/0,54              | 23 | 310 | 305x270 | 465 | 340 | 660 | 575 | 455 | 710 | 530 | 580 | 270 | 225 | 275 | 250 | 38 | 760x640x700 | 47 |
| Palladio 350 Aut  | 350/14" | 370+200/<br>0,50+0,27 | 23 | 310 | 305x270 | 465 | 340 | 659 | 610 | 515 | 675 | 530 | 573 | 270 | 225 | 275 | 250 | 40 | 870x840x750 | 55 |

TOP