

ENGLISH

TECHNICAL DATA

01	ELECTRICAL POWER	2,7 kW
03	FREQUENCY	50 / 60Hz
04	POWER SUPPLY CABLE TYPE	H07RNF
05	EXTERNAL Ø OF POWER SUPPLY CABLE	10 mm
06	VOLTAGE / POWER CABLE SECTION / CUR	230V~1PH+N+PE 3G x 1,5 mmq I = 11,8 A
11	MAX FOOD LOAD	9 Kg
02	NOMINAL HEAT INPUT	2,6 kW
14	CAVITY DIMENSIONS (W - H - D)	480x230x351 mm

ITALIANO

01	POTENZA
03	FREQUENZA
04	TIPO DI CAVO ALIMENTAZIONE
05	Ø ESTERNO CAVO DI ALIMENTAZIONE
06	TENSIONE / SEZIONE CAVI ALIMENTAZIONE
11	CARICA MAX CIBO
02	POTENZA TERMICA NOMINALE
14	DIMENSIONI CAMERA COTTURA (L - H - P)

FRANCAIS

01	PUISSANCE ELECTRIQUE
03	FREQUENCE
04	TYPE DE CABLE D'ALIMENTATION
05	Ø EXTERNE DU CABLE D'ALIMENTATION
06	TENSION / SECTION CABLE D'ALIM.
11	CHARGE MAXIMALE D'ALIMENT
02	DEBIT THERMIQUE NOMINAL
14	DIMENSIONS CHAMBRE DE CUISSON (L - A - P)

ESPAÑOL

01	POTENCIA
03	FRECUENCIA
04	TIPO DE CABLE DE ALIMENTACION
05	Ø CABLE EXTERNO DE ALIMENTACION
06	TENSION / SECCION CABLES DE ALIMENTACION
11	CARGA MAX. DE ALIMENTOS
02	POTENCIA TERMICA NOMINAL
14	DIMENSIONES CÁMARA DE COCCIÓN (A - P - A)

DEUTSCH

01	ELEKTRISCHE LEISTUNG
03	FREQUENZ
04	ZULEITUNGSKABELTYP
05	AUSSENDURCHMESSER DES VERSORGUNGSKAB
06	KABELQUERSCHNITT UND VERSORGUNGSSPANN
11	MAX. SPEISENFASSUNGSVERMOGEN
02	NOMINALE WARMELEISTUNG
14	GRÖÖE DES KOCHKAMMERS (B - H - T)



MOD: XF013



ENGLISH - DRAWINGS

1. TERMINAL BOARD COVER BOX
3. UNIPOTENTIAL TERMINAL
6. TECHNICAL DATA PLATE
12. HOT FUMES EXHAUST CHIMNEY
8. 3/4" THREAD WATER INLET
11. CAVITY DRAIN PIPE
7. SAFETY THERMOSTAT
9. 3/4" GAS INLET
2. TERMINAL BOARD POWER SUPPLY
4. PROVER CONNECTION
5. HOOD/STEAM CONDENSER CONNEC
10. ROTOR KLEAN CONNECTION
13. ACCESSORIES CONNECTION
14. OVEN CONNECTION CABLE
15. CABLE PRESS

ITALIANO - DISEGNI

1. SCATOLA COPRI MORSETTIERA
3. MORSETTO EQUIPOTENZIALE
6. TARGHETTA DATI TECNICI
12. USCITA FUMI CALDI
8. INGRESSO ACQUA 3/4"
11. SCARICO CAMERA COTTURA
7. TERMOSTATO DI SICUREZZA
9. INGRESSO GAS 3/4"
2. MORSETTIERA ALIMENTAZIONE
4. COLLEGAMENTO LIEVITATORE
5. COLLEGAMENTO CAPPA/ABBATTITO
10. INGRESSO ROTOR KLEAN
13. COLLEGAMENTO ACCESSORI
14. CAVO COLLEGAMENTO FORNO
15. PRESSECAVO

LASCIARE STACCATO DI 10 cm IL FORNO DAL MURO

FRENCH - ENCUMBREMEN

1. CHAUMARD
3. SUPPORT BORNE EQUIPOTENTIELL
6. PLAQUETTE SEGNALETIQUE
12. SORTIE DES FUMÉES CHAUDES
8. ARRIVÉ D'EAU FIELT 3/4"
11. SORTIE DE L'EAU RACCORD
7. THERMOSTAT DE SÉCURITÉ
9. ARRIVÉ DU GAS 3/4"
2. BOITE A BORNES D'ALIMENTATION
4. JONCTION DE L'ETUVE
5. JONCTION DE L'HOTTE/CONDENSAT
10. ENTREE ROTOR KLEAN
13. JONCTION DES ACCESSOIRES
14. CABLE DE CONNEXION DU FOUR
15. PRESSE CABLE

PLACER LE FOUR À UNA DISTANCE DE 10 cm DU MUR

SPANIOL - DISEÑOS

1. PASA CABLE
3. SEDE BORNE EQUIPOTENCIAL
6. TARJETA DE CARACTERISTICAS TE
12. SALIDA HUMOS CALIENTES
8. ENTRADA DE AGUA 3/4"
11. DESCARGA CAMARA DE COCCION
7. TERMOSTATO DE SEGURIDAD
9. ENTRADA DE GAS 3/4"
2. CAJA DE CONEXION
4. CONEXION FERMENTADOR
5. CONEXION CAMPANA/CONDENSAD
10. INGRESO ROTOR KLEAN
13. CONEXION ACCESORIOS
14. CABLE CONEXION HORNO
15. ENCHUFE

MANTENER SEPARADO 10 CM EL HORNO DE LA PARED

DEUTSCH - ZEICHNUNGEN

1. KLEMMLEISTENANSCHLUSS
3. GLEICHPOTENTIELLE KLAMMER
6. TYPENSCHILD
12. ABZUGSHAUBE
8. WASSEREINZUG 3/4 GEWINDE
11. WASSERAUSLASS GEWINDE
7. SICHERHEITSTHERMOSTAT
9. GAS EINZUG 3/4" GEWINDE
2. ZULEITUNGSKLEMMLEISTE
4. GÄRSCHRANKVERBINDUNG
5. ABZUGSHAUBEVERBINDUNG
10. ROTOR KLEAN EINGANG
13. ZUBEHÖRTEILENVERBINDUNG
14. OFENSVERBINDUNGSKABEL
15. PRESSE-ANSCHLUSSKABEL

DRAWING

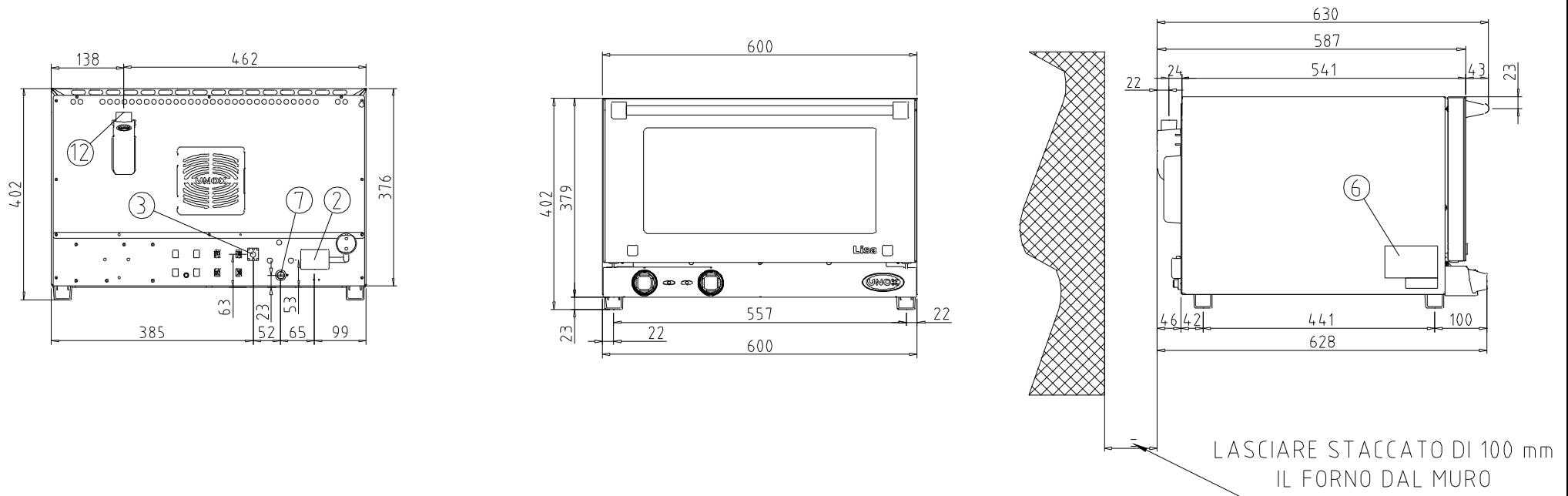

ENGLISH - WIRING DIAGRAMS

MO TERMINAL BOARD
TSI SAFETY THERMOSTAT
TM TIMER
TE THERMOSTAT
M MOTOR
R HEATING ELEMENT
H OVEN LIGHT
S PILOT LIGHT
C ELECTRIC CONDENSER
IM REVERSING GEAR
uP DOOR MICROSWITCH
RE ENERGY REGULATOR
P PUSH BUTTON
INT SWITCH

ITALIANO - SCHEMI ELETTRICI

MO MORSETTIERA
TSI TERMOSTATO SICUREZZA
TM TIMER
TE TERMOSTATO LAVORO
M MOTORE
R RESISTENZA
H LUCE FORNO
S LUCE SPIA
C CONDENSATORE
IM INVERTITORE DI MARCIA
uP MICRO INTERRUPTORE PORTA
RE REGOLATORE ENERGIA
P PULSANTE
INT INTERRUPTORE

FRENCH - SCHEMAS ELECTRIQUES

MO BOITE A BORNES
TSI THERMOSTAT DE SECURITE'
TM TIMER
TE THERMOSTAT DE TRAVAIL
M MOTEURS DES TURBINES
R RESISTANCE
H LAMPE DU FOUR
S LAMPE TEMOIN
C CONDENSATEUR
IM INVERSEUR DE MARCHÉ
uP MICRO INTERRUPTEUR DE PORTE
RE REGULATEUR D' ENERGIE
P POUSSOIR
INT INTERRUPTEUR

SPANISH - ESQUEMAS ELECTRICOS

MO CAJA CONEXIONES-REGLETA
TSI TERMOSTATO DE SEGURIDAD
TM TIMER
TE TERMOSTATO DE TRABAJO
M MOTOR
R RESISTENCIA
H LUZ HORNO
S LUZ PILOTO
C CONDENSADOR
IM INVERSOR DE MARCHA
uP MICRO INTERRUPTOR PUERTA
RE REGULADOR ENERGIA
P PULSADOR
INT INTERRUPTOR

GERMAN - SCHALTPLAN

MO KLEMMLEISTE
TSI SICHERHEITS THERMOSTAT
TM TIMER
TE THERMOSTAT
M MOTORVENTILATOR
R WIDERSTAND
H LICHT DES OFENS
S KONTROLLICHT
C KONDENSATOR
IM WENDEGETRIEBE
uP MIKROTÜRSCHALTER
RE ENERGIEREGLER
P TASTE
INT SCHALTER

CONTROL SECTION

