



4.0-6.0 Kw

50/60Hz
400V-3Ph

Miscelatori planetari da 100 e 160lt. Macchine potenti e robuste specificamente studiate per laboratori artigianali di medie e grandi dimensioni. Versioni con touch screen e 50 programmi

100 and 160 l planetary mixers. These machines are powerful and sturdy and were specifically designed for medium and large artisan laboratories. Available models with touch-screen and 50 programs

Mezcladoras planetarias de 100 y 160 litros. Máquinas poderosas y robustas estudiadas específicamente para talleres artesanales de dimensiones medianas y grandes. Versiones con touch screen y 50 programas

Mélangeurs planétaires de 100 et 160 l. Machines puissantes et robustes expressément conçues pour les laboratoires artisanaux de taille moyenne et grande. Versions avec écran tactile et 50 programmes

Планетарные миксеры на 100 и 160 л. Мощное и прочное оборудование разработано специально для средних и больших предприятий. Модели с сенсорным экраном и 50-ью программами

	100	160
Capacità Vasca - Bowl Capacity	100 lt.	160 lt.
Regolazione velocità - Speed regulation	Inverter / Inverter	
Trasmissione - Transmission	Scatola ad ingranaggi / Gear box	
Protezione vasca - Bowl guard	Removibile / Removable	
Rimozione vasca - Bowl removal	Anche con presenza utensili / Without removing tools	

× Standard ○ Optional

Specifiche tecniche / Technical specifications



	Bullino	Bull 20	Bull 20 C	Bull 40	Bull 40 P	Bull 60	Bull 60 P	Bull 100	Bull 160
Struttura in acciaio verniciata Steel powder painted body	×	×	×	×	×	×	×	×	×
Regolazione velocità con inverter Inverter speed regulation	×	×	×	×	×	×	×	×	×
Timer meccanico Mechanic timer		×	×	×	×	×	×	×	×
Sollevamento vasca manuale Manual bowl lifting	×	×	×	×	×	×	×		
Sollevamento vasca elettrico Electric bowl lifting				○	○	○	○	×	×
Vasca inox Stainless steel bowl	×	×	×	×	×	×	×	×	×
Carrello vasca Bowl trolley				○	○	○	○		
Vasca con ruote Bowl with wheels								×	×
Riduzione vasca Bowl reduction kit				○	○	○	○		
Utensili (Frusta, spirale e spatola) Tools (Whisk, spiral and beater)	×	×	×	×	×	×	×	×	×
Faschiatore Scraper				○	○	○	○	○	○
Gancio Hook				○	○	○	○	○	○
Protezione amovibile Removable guard		×	×	×	×	×	×	×	×
Versioni Inox Stainless Steel version				○	○	○	○	○	○
Touch screen 50 programmi Touch-screen 50 programs								○	○
Condizioni massime di utilizzo* (Kg) Maximum operational limitations* (Kg)	3,5	11	11	20	20	30	30	60	95

(*) Pasta frolla(W240-250, P/L 0.45 – 0.65), utilizzo in discontinuo su un turno di lavoro / Short pastry(W240-250, P/L 0.45 – 0.65), intermittent use on a working shift



BULLino

Bull 20

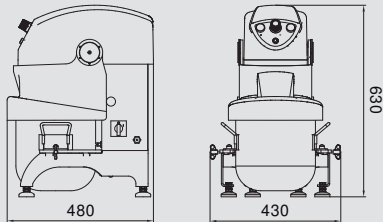

40 Kg

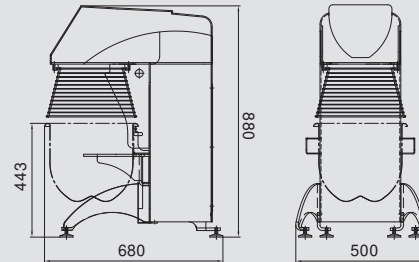

120 Kg

Bull 20 C

Bull 40/60

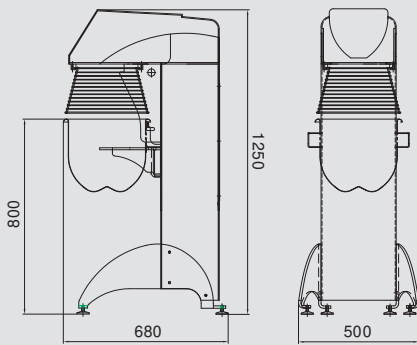

130 Kg

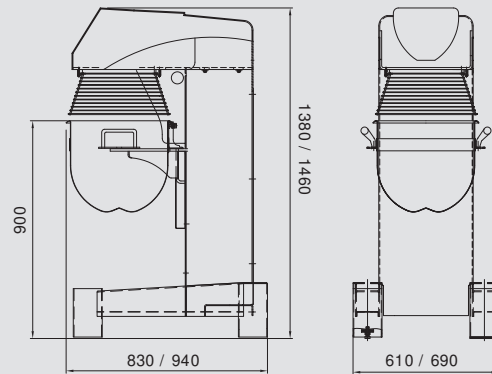

203 / 277 Kg

Bull 100/160

Soll

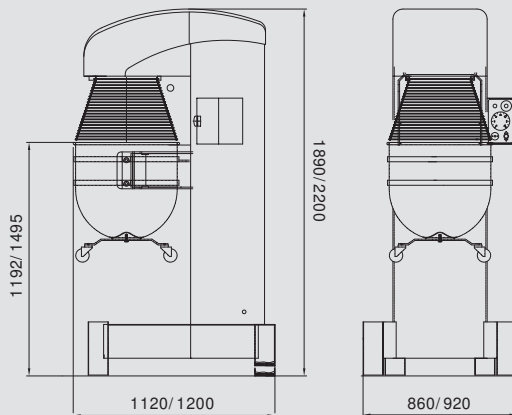

580 / 808 Kg

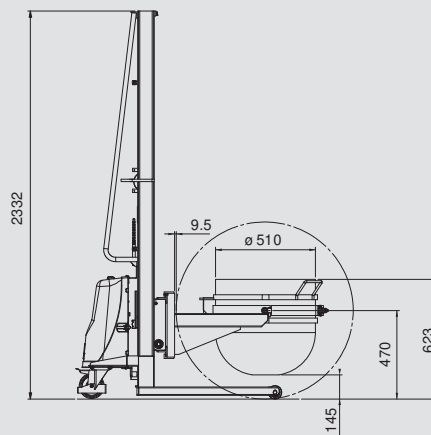

237 Kg