

**IP 50 M Y14**

Gambe con ruote opzionali
Optional legs with wheels

**IP 30 M Y14**

IP 30-50 M Y14

impastatrici per carne

meat mixers



- Costruzione in acciaio inox Aisi 304.
- Potente motore.
- Riduttore a bagno d'olio con ingranaggi elicoidali temperati e rettificati.
- Sistema di protezione ingranaggi con doppio paraolio.
- Coperchio con micro di sicurezza.
- Pala in acciaio inox Aisi 304 facilmente rimovibile senza attrezzi.
- Sportello vasca apribile per rimozione pala e impasto.
- Comandi in acciaio inox IP 67 con inversione.

Opzioni:

- Gambe inox basse, medie e alte con ruote.
- Tramoggia aggiunta ingredienti.

- AISI 304 stainless steel body.
- Powerful.
- Oil bath reducer with hardened and ground helical gears.
- Gear box with double sealing system.
- Safety microswitch on the cover.
- Removable AISI 304 stainless steel mixing arm (no tools required).
- Front outlet opening for shaft removal and product unload.
- Stainless steel IP 67 protection rated controls with reverse.

Optionals:

- Short, medium, long legs with wheels.
- Feeding tray to add ingredients.

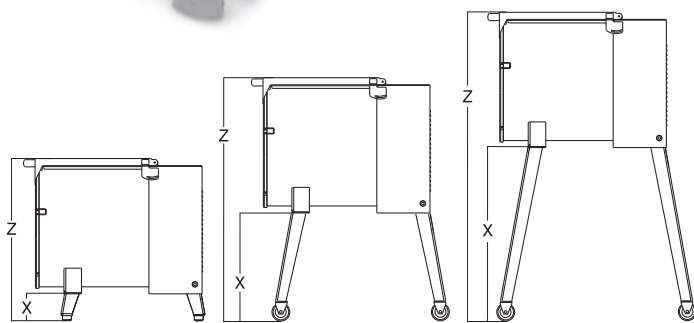

Opzione tramoggia per aggiunta ingredienti
Optional feed tray for add ingredients

**Gambe opzionali / Optional legs**

Gambe basse + piedino
Short legs + feet

IP 30 M Y14

X: 150 mm / Z: 650 mm

IP 50 M Y14

X: 150 mm / Z: 720 mm

Gambe medie + ruote + freno
Medium legs + wheels + brake

IP 30 M Y14

X: 440 mm / Z: 940 mm

IP 50 M Y14

X: 440 mm / Z: 1010 mm

Gambe alte + ruote + freno
Longer legs + wheels + brake









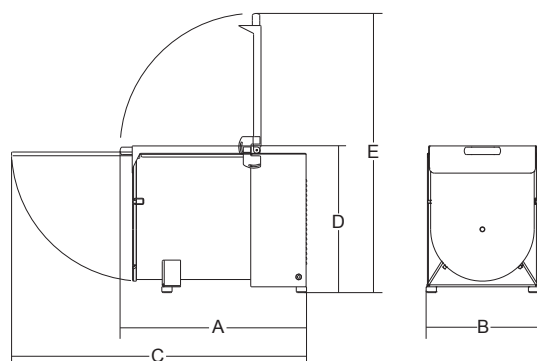



IP 30 M Y14

X: 610 mm / Z: 1110 mm

IP 50 M Y14

X: 610 mm / Z: 1180 mm



												
	watt/HP		mm	lit/kg	mm	mm	mm	mm	mm	kg	mm	kg
IP 30 M Y14	1ph 1.100/1.5 3ph 1.472/2	1ph/3ph	300x400	42/30	680	365	1120	530	975	49	750x580x800	59
IP 50 M Y14	1ph 1.100/1.5 3ph 1.472/2	1ph/3ph	410x480	88/50	750	465	1250	595	1120	59	850x840x830	74