



MANTEGNA



YouTube

- Linea arrotondata priva di spigoli e facile da pulire
- Perno di scorrimento, cromato rettificato e lappato
- Boccole di scorrimento autolubrificante
- Paracolpo su carrello in gomma vulcanizzata
- Coperchio supporto vela smontabile
- Parafetta rimovibile in acciaio inox con incastro rapido a baionetta
- Tutte le minuterie acciaio inox
- Copertura inferiore con accesso diretto ai componenti elettrici
- Pulsanti IP 67 in acciaio inox
- Affilatoio con vaschetta inferiore di protezione
- Sistema di tenuta stagna su puleggia
- 48 mm di distanza fra lama e corpo macchina
- Estrattore lama di serie

MANTEGNA

- Manopole in plastica
- Piedini in gomma

MANTEGNA TOP

- Manopole alluminio
- Piedini in alluminio telescopici con base in gomma
- Kit manutenzione e sanificazione in pratica valigetta

MANTEGNA VCO

- Particolarmente richieste nei mercati nordici
- Piatto a vasca per tagliare ogni tipo di prodotto
- Staffa blocca prodotto in alluminio smontabile
- Staffa con chiodi in acciaio e denti fresati sul lato lama
- Disponibile anche nella versione con braccetto mobile

- Innovative rounded design and no sharp edges or visible screws
- Chrome plated ground and lapped slide rod
- Self lubricating slide rod bushings
- Vulcanised rubber stops on carriage
- Removable support cover for thickness gauge plate
- Stainless steel slice deflector with snap-on bayonet fitting
- Stainless steel screws and fittings
- Bottom cover for accessing electrical components
- Stainless steel pushbuttons with IP67 protection rating
- Built in sharpening tool with bottom protection
- Enclosed and sealed belt pulley
- 48 mm distance between blade and motor
- Standard Blade Removal Tool (BRT)

MANTEGNA

- Plastic knobs
- Rubber feet

MANTEGNA TOP

- Knobs aluminum
- Aluminium telescopic feet with rubber base
- Maintenance tool kit

MANTEGNA VCO

- Specially required by the Northern European marketplace
- Product table designed to slice all types of products
- Removable aluminum end weight
- Designed with grooves: nails underneath
- Available with double articulating arm on end weight



MANTEGNA 300 BS1 TOP



MANTEGNA 300 BS1



MANTEGNA 300 VCS

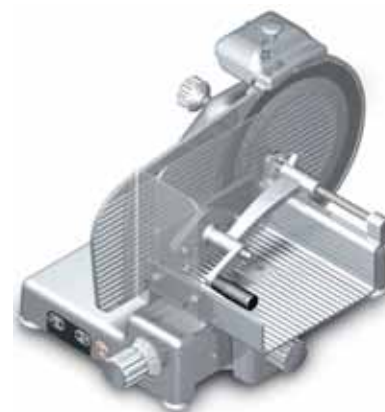

MANTEGNA 300 VCO BM TOP



Zavorra smontabile BS1
Removable food pusher BS1

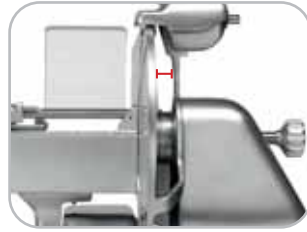

Ampio spazio tra lama e corpo macchina
More space between blade and body machine



Zavorra smontabile VCS
Removable food pusher VCS



Comandi di serie
Standard controls

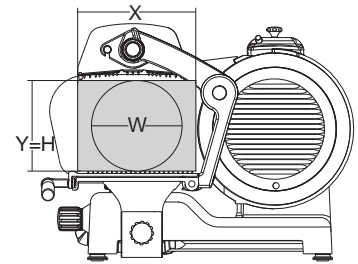
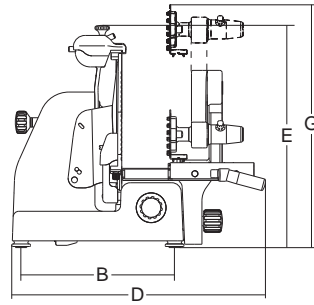
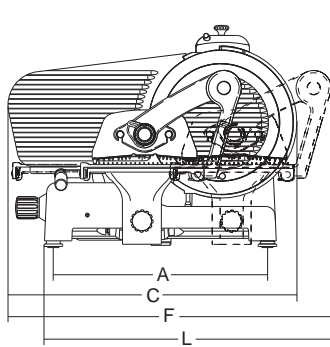

						A	B	C	D	E	F	G	L	X	Y	H	W			
	mm-inch	watt-Hp	mm	mm	mm	mm	mm	mm	mm	mm	mm	mm	mm	mm	mm	mm	mm	kg	mm	kg
Mantegna 300 BS1	300/12"	275/0,37	29	310	300x270	468	338	635	600	500	750	695	650	270	230	230	230	36.5	870x840x750	51.5
Mantegna 300 VCS	300/12"	275/0,37	29	310	340x250	468	338	635	685	500	720	560	610	250	225	225	225	36	870x840x750	52
Mantegna 300 VCO	300/12"	275/0,37	29	310	280x260	468	338	635	652	500	677	520	610	260	230	230	230	35	870x840x750	50
Mantegna 300 VCO BM	300/12"	275/0,37	29	310	280x260	468	338	635	585	500	677	660	610	260	230	230	230	36	870x840x750	51
Mantegna 330 BS1	330/13"	275/0,37	29	310	300x270	468	338	645	600	515	750	705	630	270	245	245	245	37	870x840x750	52
Mantegna 330 VCS	330/13"	275/0,37	29	310	340x250	468	338	645	685	515	720	560	580	250	235	235	235	37	870x840x750	53
Mantegna 330 VCO	330/13"	275/0,37	29	310	280x260	468	338	645	652	515	677	520	585	260	245	245	245	36	870x840x750	51
Mantegna 330 VCO BM	330/13"	275/0,37	29	310	280x260	468	338	645	585	515	677	660	585	260	245	245	245	37	870x840x750	52
Mantegna 350 BS1	350/14"	370/0,50	29	310	300x270	468	338	660	600	530	750	715	630	270	255	255	255	38	870x840x750	53
Mantegna 350 VCS	350/14"	370/0,50	29	310	340x250	468	338	660	685	530	720	560	580	250	245	245	245	38	870x840x750	54
Mantegna 350 VCO	350/14"	370/0,50	29	310	280x260	468	338	660	652	530	677	520	585	260	255	255	255	38	870x840x750	53
Mantegna 350 VCO BM	350/14"	370/0,50	29	310	280x260	468	338	660	585	530	677	660	585	260	255	255	255	38	870x840x750	53

TOP



MANTEGNA 300 VCO TOP



MANTEGNA 300 VCS TOP