



PALLADIO AUTOMECC



YouTube

Caratteristiche affettatrice come la Palladio

- Struttura automatismo in acciaio inox saldato e arrotondato
- Trascinamento carrello con sistema meccanico a biella
- Motore trascinamento ventilato a comando separato con riduttore a bagno d'olio
- Comandi separati per lama e automatismo
- Possibilità di sblocco automatismo per un funzionamento manuale
- 2 sistemi di controllo:
 - Standard on/off
 - VV: on/off con variatore di velocità
- Produzione fette al minuto:
 - Palladio Automec: 37
 - Palladio Automec VV: 40 - 50

Opzionali:

- Leva sollevamento
- Contafette
- Tubo per taglio verdure
- Slitta per il taglio del pesce da fissare sul piatto Uniko:
 - Dimensioni max prodotto mm 170 x 88h.
 - Inclinazione taglio regolabile fino a 50°
 - Temperatura del prodotto vicina allo 0, meglio se -5° / -6°

PALLADIO 350 AUTOMECC FROZEN

- Appositamente studiata per il taglio di carni congelate fino a -12 °C
- Produzione fette al minuto 29

The Palladio Automec series offers the same outstanding features of the Palladio series adding:

- *Welded and rounded stainless steel automatism structure*
- *Piston/rod system carriage motion*
- *Fan-cooled carriage motion motor with commercial-grade oil bath reduction*
- *Blade and carriage motion powered by separate controls*
- *An easily accessible switch arm can convert the unit from automatic to manual operation*
- *Two control systems:*
 - *Standard on/off*
 - *VV: on/off with speed control*
- *Output slicers per minute:*
 - *Palladio Automec: 37*
 - *Palladio Automec VV: 40 - 50*

Options:

- *Lifting lever*
- *Slice counter*
- *Vegetables cote*
- *Convenient fish cutting accessory can be fixed on the Uniko hopper:*
 - *Maximum product dimensions 170 x 88 h mm.*
 - *Adjustable cutting inclination up to 50°*
 - *Product temperature suggested close to 0, preferably -5 ° / -6 ° C.*

PALLADIO 350 AUTOMECC FROZEN

- *Especially designed for slicing frozen meat up to -12 °C*
- *Output slicers per minute 29*



Leva sollevamento, opzionale
Lifting lever, optional



Contafette opzionale
Optional slice counter



Piatto Uniko
Uniko hopper

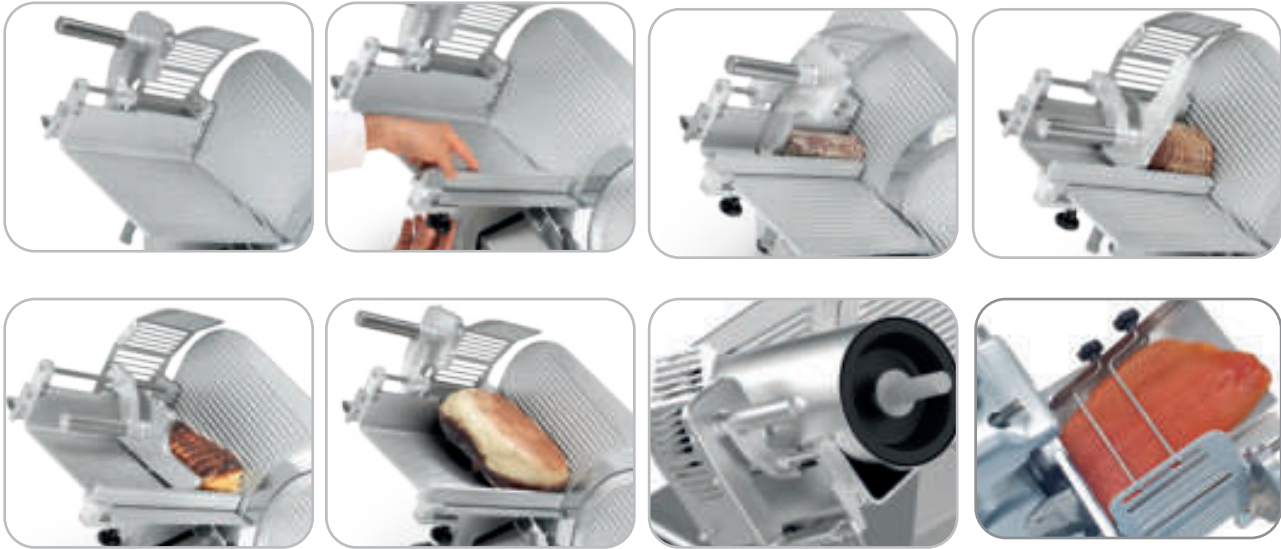

Tubo verdure opzionale
Optional vegetables tube

Slitta pesce Poseidon opzionale
Optional Poseidon fish cutting

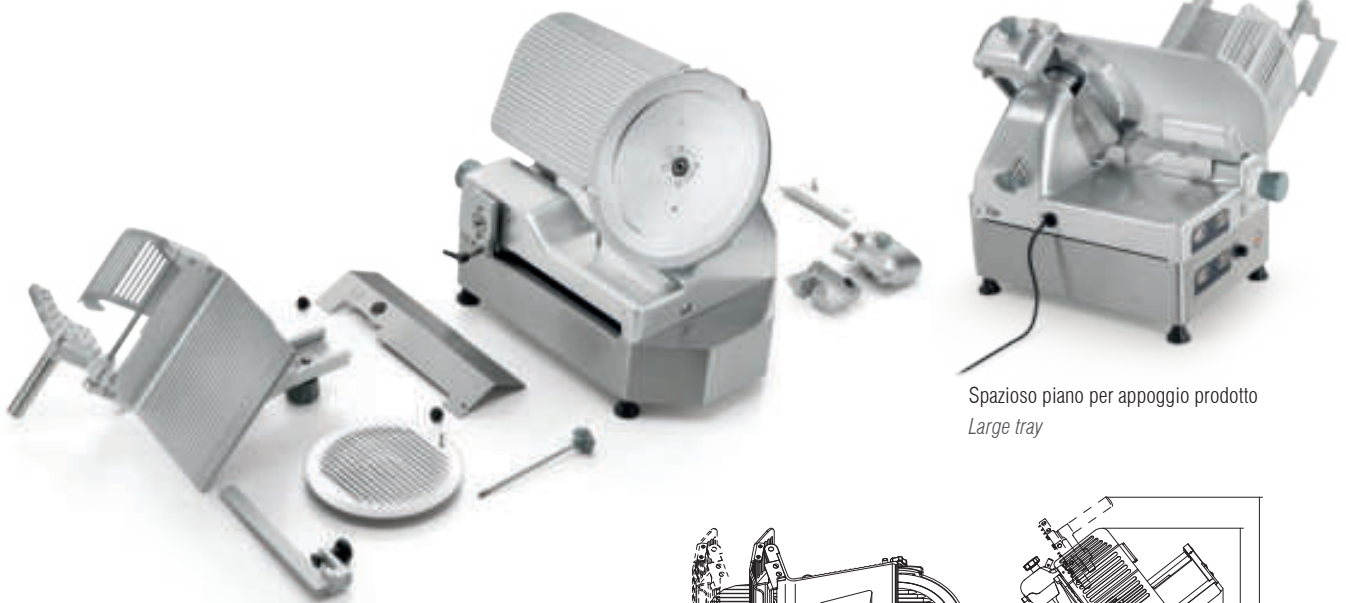

Spazioso piano per appoggio prodotto
Large tray

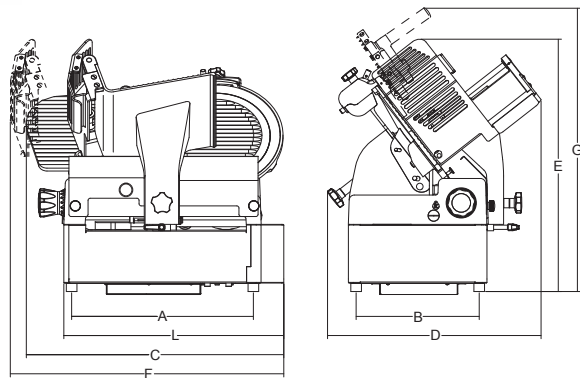
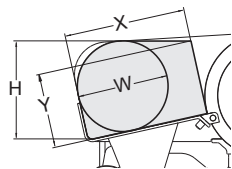

	mm-inch	watt-Hp	mm	mm	mm	mm	mm	mm	mm	mm	mm	mm	mm	mm	mm	mm	mm	kg	mm	kg
Palladio 300 Automec	300/12"	275/180/ 0,37/0,24	23	310	305x270	465	340	685	575	575	751	630	615	270	190	240	220	55	840x840x750	70
Palladio 330 Automec	330/13"	275+180/ 0,37+0,24	23	310	305x270	465	340	690	575	575	756	630	615	270	210	260	240	56	870x840x750	71
Palladio 350 Automec	350/14"	370+180/ 0,50+0,24	23	310	305x270	465	340	690	575	575	756	630	615	270	225	275	250	57	870x840x750	72
Palladio 350 Automec Frozen	350/14"	370+180/ 0,50+0,24	23	310	305x270	465	340	690	575	575	756	630	615	270	225	275	250	57	870x840x750	72

VW